

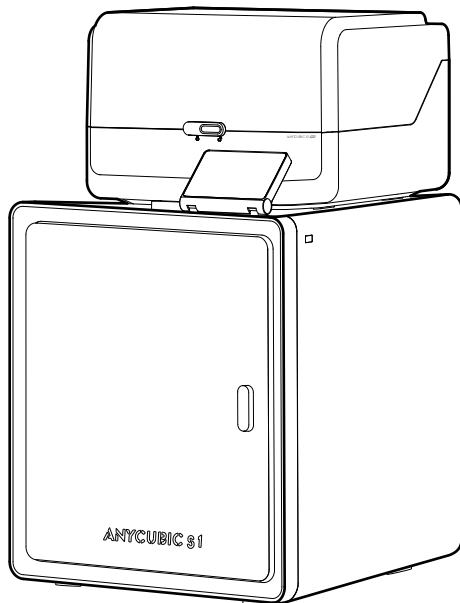

Anycubic Kobra S1 Combo User Manual



Installation Video

The product picture is for reference only. Please refer to the actual product.

Dear Customer,

Thank you for choosing **ANYCUBIC** products.

Maybe you are familiar with 3D printing technology or have purchased **ANYCUBIC** printers before, but we still highly recommend that you read this manual carefully. The installation techniques and precautions in this manual can help you avoid any unnecessary damage or frustration.

Please visit <https://support.anycubic.com/> to contact us if you have any question. You can also gain more information such as software, videos, models from the website.



ANYCUBIC APP



ANYCUBIC Wiki



ANYCUBIC Support Center



Multi-country User Manual

Team **ANYCUBIC**

Copyrighted by "Shenzhen Anycubic Technology Co., Ltd ", all rights reserved.

Content

1	Product Overview	1
2	Machine Installation	4
	Unlock ACE Pro	4
	Unlock Printhead	6
	Unock Hot Bed	6
	Install Spool Holder	7
	Install ACE Pro	8
	Install Activated Carbon	10
3	Power-on Guide	11

4	Print Model	13
5	Printer Binding	14
	APP	14
	Anycubic Slicer	15
6	Other Function Descriptions	18
7	Attention	20

Product Overview

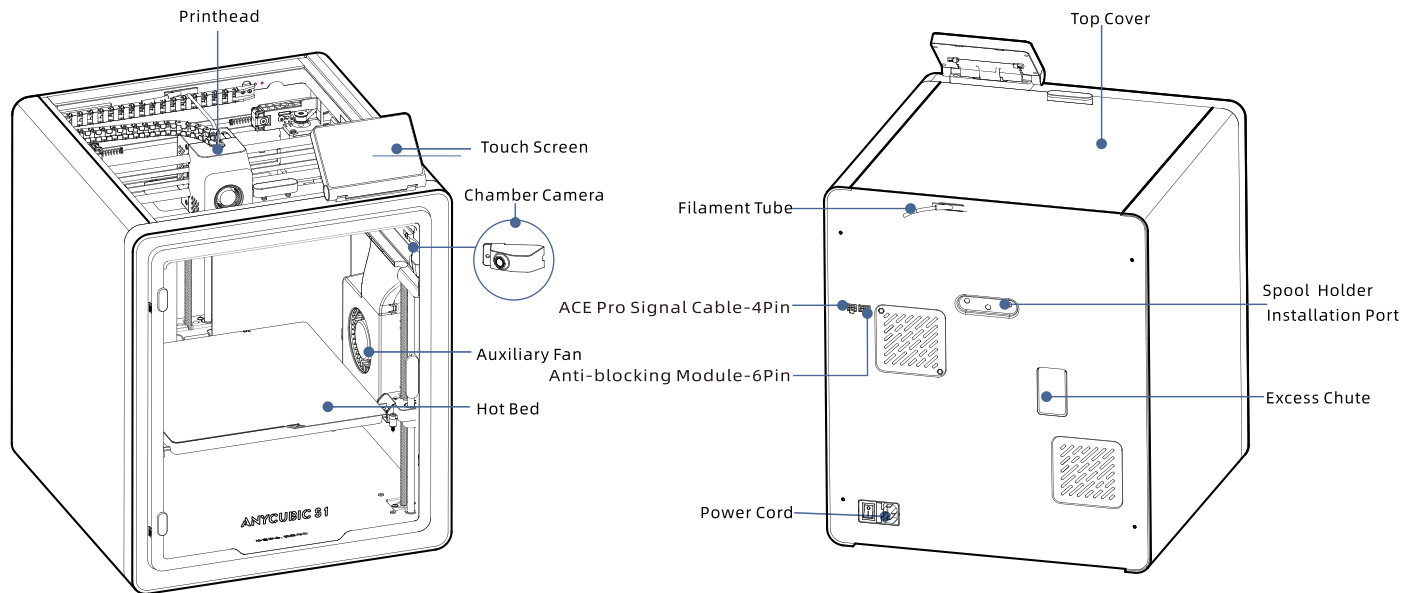

Product Overview

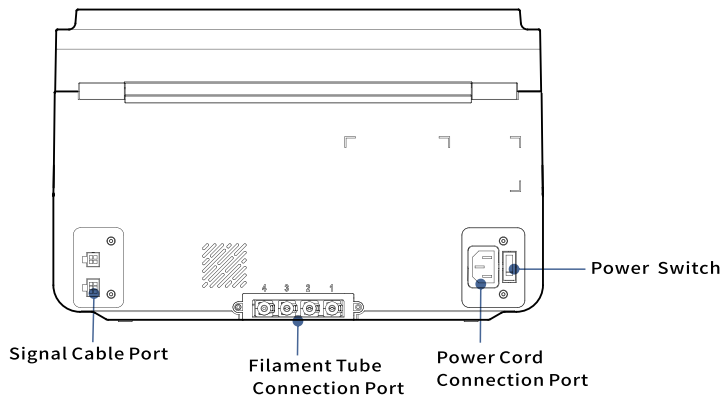
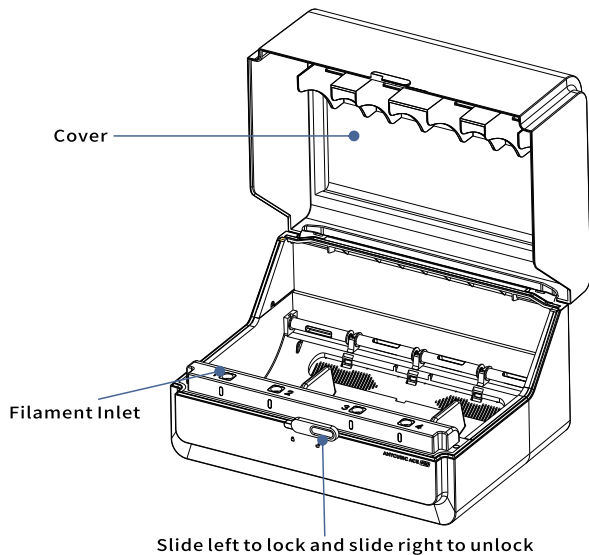

Avoid using ACE Pro to print flexible materials, including TPU, TPE, or absorbent PVA, avoid using materials that are too hard (too high modulus) or too brittle (not enough toughness), please use external spool holder to print these filament.

Packing List

The following pictures are for reference only. Please refer to the actual object.



Kobra S1 Printer

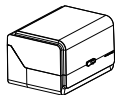

Anycubic Color Engine Pro (ACE Pro)



Spool Holder



Signal Cable (1pcs)



Filament Tube (4pcs)



Power Cord (2pcs)



Anti-blocking Module



Screws M2.5*25 (2pcs)



Screws M3*6 (2pcs)



U-Disk (1Pcs)



2.5/2.0/1.5



Filament Sample



Nozzle Cleaner

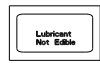

Grease



Activated Carbon (1Pcs)



Nozzle Cleaning Module (1Pcs)



Nozzle Silicone Part (1Pcs)



Cable Organizer (2Pcs)

Technical Specification

Printing

Technology: FDM (Fused Deposition Modeling)

Build Size: 250 mm (L) × 250 mm (W) × 250mm (H)

Layer Thickness: 0.08 - 0.28mm

Positioning Accuracy: X / Y / Z 0.0125 / 0.0125 / 0.0008 mm

Extruder Quantity: Single

Nozzle Diameter: 0.4 mm

Supported Materials: PLA/TPU/PETG/ABS/ASA

Software

Slicing Software: Anycubic Slicer Next/Orca Slicer

Software Input Formats: .STL/.OBJ/.3mf

Software Output Formats: GCode

Connectivity: U-DISK, AC Cloud, Anycubic Slicer Next

Electrical

Power Input: 100-120V~ /200-240V~

Rated Power: 325W/1300W

WIFI

Frequency Band: 2.4G (2.400-2.4835GHz)

Working Mode: STA

Physical Dimensions

Printer Dimensions: 400mm (L) × 410mm (W) × 490 mm (H)

Net Weight: ~18kg

ACE Pro Dimensions: 365.9mm (L) × 282.8mm (W) × 234.5 mm (H)

ACE Pro Net Weight: ~4.6kg

Dimensions of Printer and ACE Pro Footprint:

420mm (L) × 530mm (W) × 710 mm (H)

Machine Installation

Unlock ACE Pro

For the installation instruction video, please scan the QR code on the right.

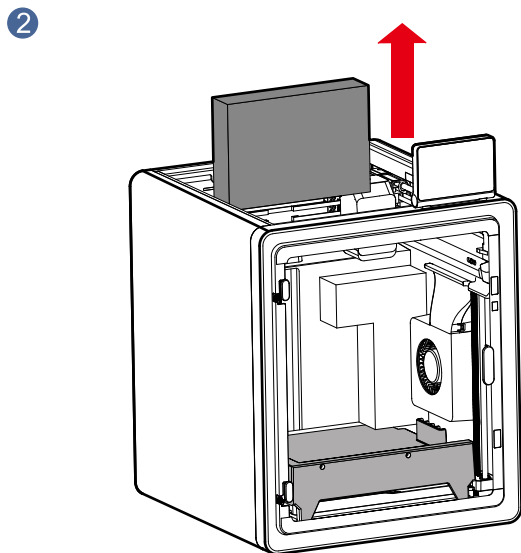
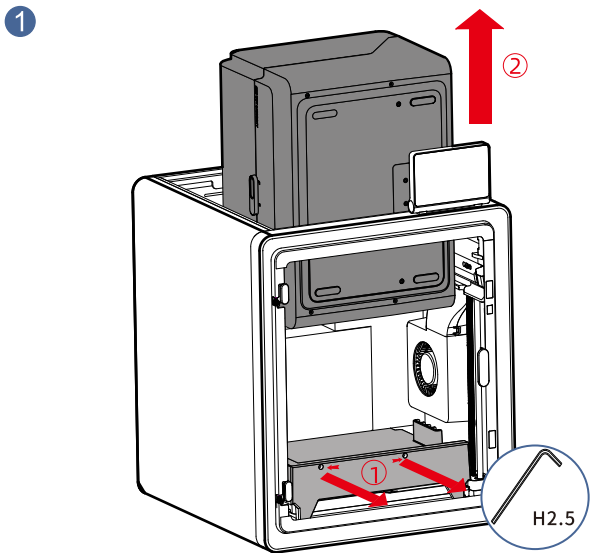

1. Open the printer cover, and use Allen Key H2.5 to remove the two screws marked in red as pictured.

Take out the accessory box by sliding it out through the top.

4 2. After completing the above operations, take out the ACE Pro through the top.

*It is enough to loosen the screws to a certain extent, there is no need to completely remove the screws.

Unlock ACE Pro

3

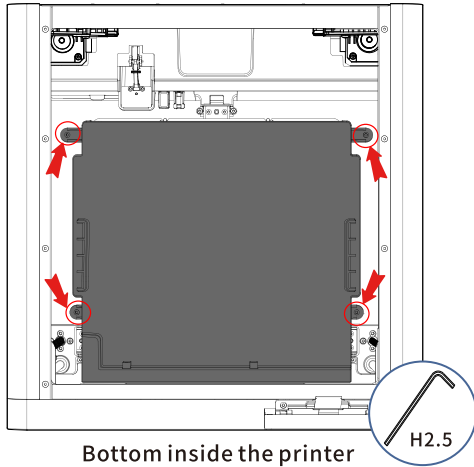

As shown by the arrows, use Allen Key H2.5 to remove the four screws marked in red circles.

*It is enough to loosen the screws to a certain extent, there is no need to completely remove the screws.

4

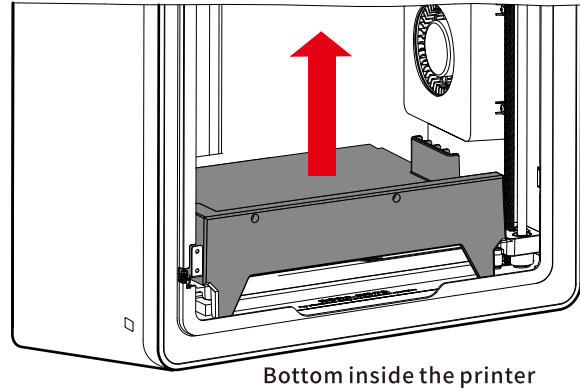

Take out the ACE Pro cushioning.

Unlock Printhead

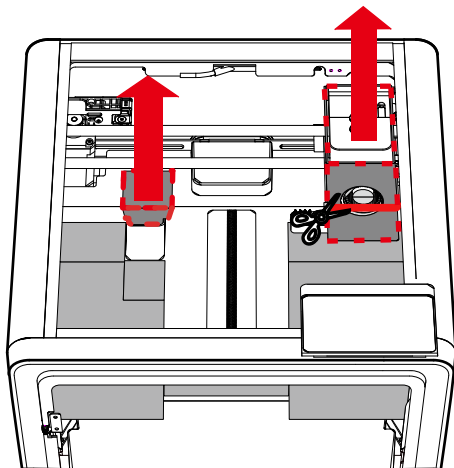

Top of the printer

1. Cut the zip tie securing the printhead, remove the cardboard from the printhead.
2. Remove the foam.

Unlock Hot Bed

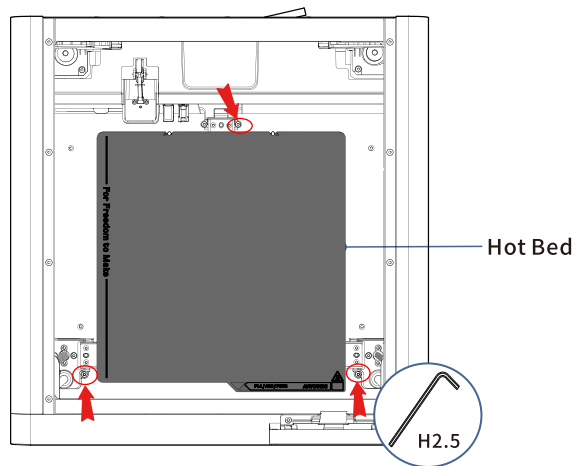

Bottom inside the printer

As shown by the arrows, use Allen Key H2.5 to remove the three screws marked in red circles.

Install Spool Holder (skip this step if printing in multiple colors)

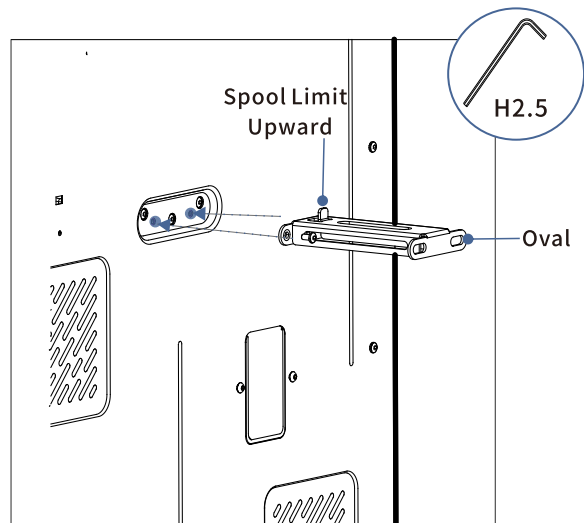
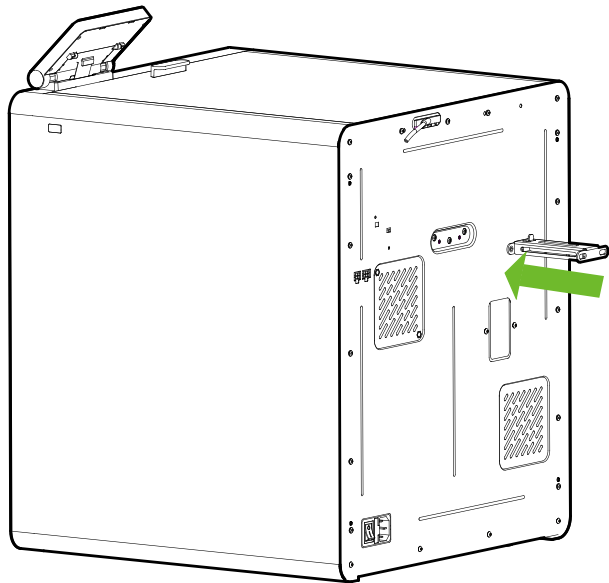

Secure the spool holder with M3*6 screws from the accessory box.

Install ACE Pro

1. Place ACE Pro on top of Kobra S1.

2. Insert the 4-pin end of the signal cable into the printer, and insert the 6-pin end into the hole in the left corner of ACE Pro.

3. Use M2.5*25 screws to fix the filament hub module on the back of the printer and insert the cable into the port (use Allen Key H2.0).

4. Insert the suspended filament tube into the port.

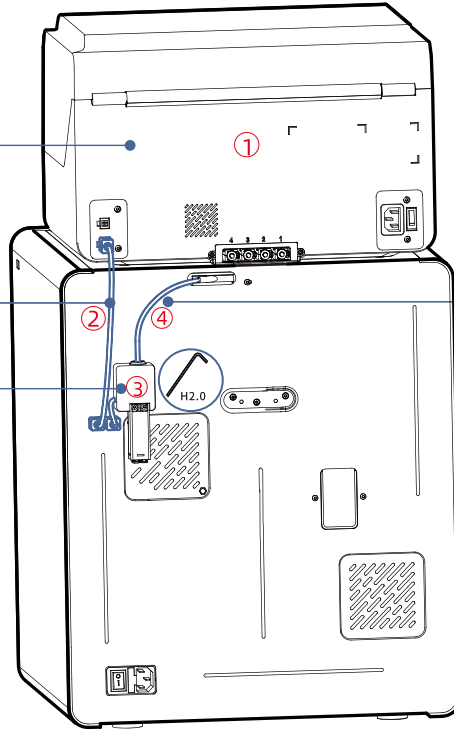

Install ACE Pro

5. Insert all four teflon tubes into the filament hub.

Note: Please enter the teflon tube to the end.

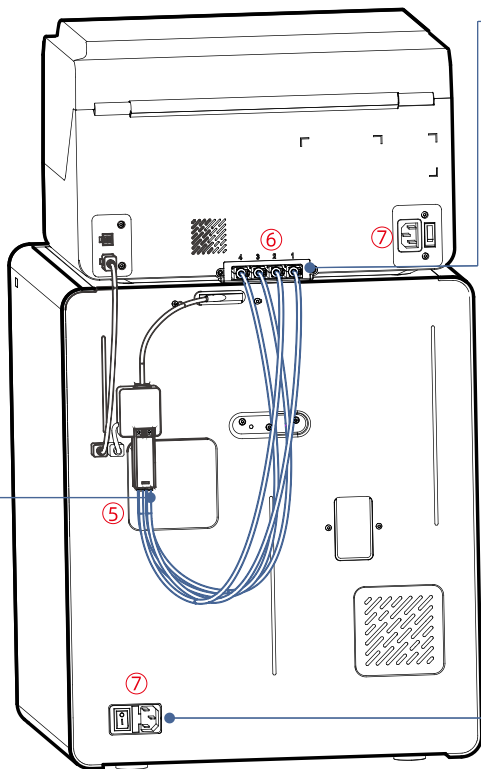

6. First, remove the four blue clips from the connection ports of the teflon tubes. Insert the teflon tubes into the ports, then reinstall the four blue clips back into their original positions (Note: teflon tubes are matched in no order).

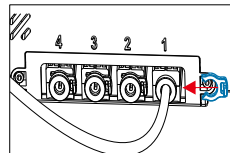
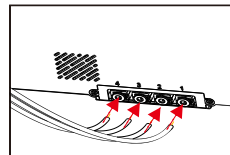
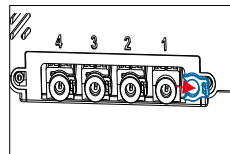

7. After completing the above operations, use the power cord to power the printer and ACE Pro.

Install Activated Carbon

Take out the activated carbon from the accessories box, and tear off the vacuum packaging, place it in the filter box inside the printer.

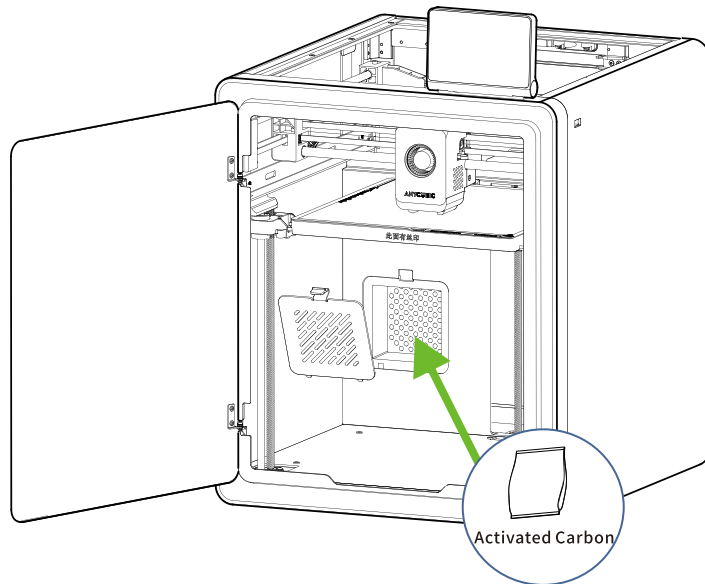

Power-on Guide

① Main Interface

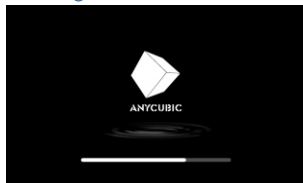

② Language

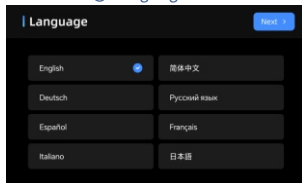

③ Area

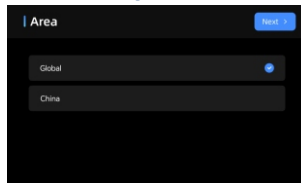

④ Network

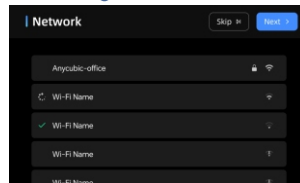

⑤ Cloud

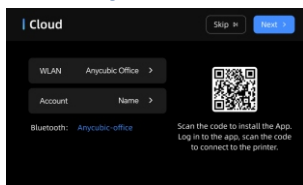

⑥ Using Guidance

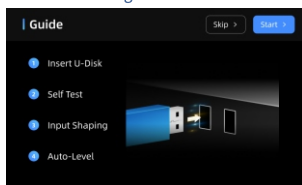

⑦ Insert U-Disk

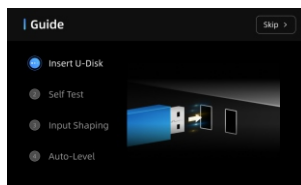

⑧ Self Test

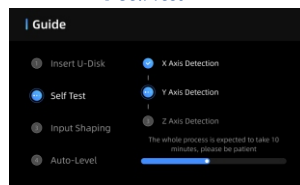

⑨ Auto-Level

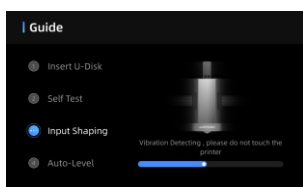

⑩ Vibration Compensation

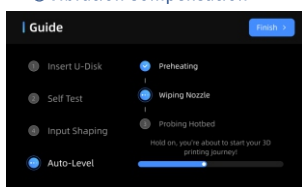

Note: The current interface is for reference only. Due to ongoing feature upgrades, please refer to the UI of the latest firmware release for accurate information.



Loading Filament

1. Place at least one roll of filament in ACE Pro.
 2. Insert the filament into the filament inlet, and ACE Pro will automatically pre-load the filament after detecting it.
 3. Press the [Filament] interface, click to select a filament, select the corresponding material and color.
- If you use Anycubic RFID filament, the filament color and material will be automatically identified.
4. After completing the above operations, click [Extrude], wait for the nozzle to heat to the preset temperature, and the filament will be extruded from the nozzle.

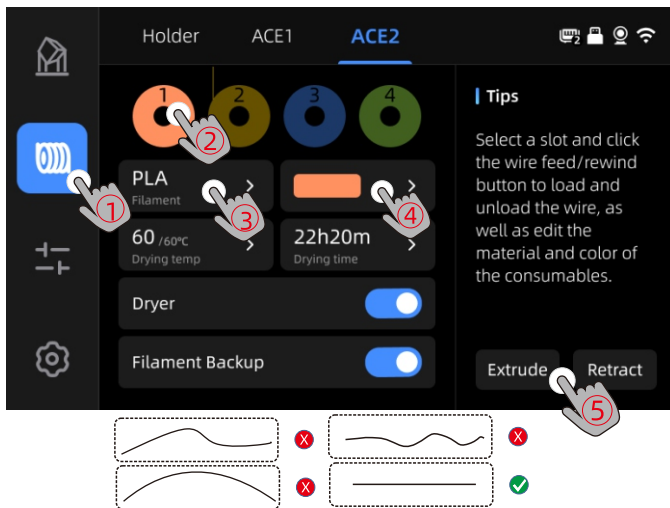
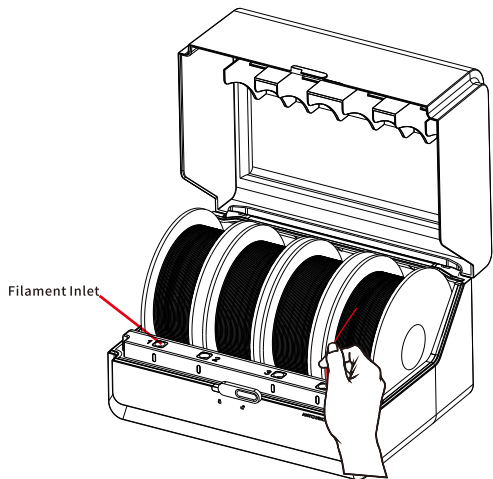

Note: 1. Before inserting the filament into the filament inlet, make sure to straighten the end of the filament.
2. It is recommended to use plastic filament trays first to achieve better printing smoothness. If you use paper trays, the tray may slip and produce debris due to friction. It is recommended to use it with an adapter ring. (Please download the adapter ring from Makeronline)



First Print

Makeronline QR Code: Models can be downloaded via Makeronline



1) Select a model from the local or U-DISK and start printing.

*We recommend using one of the pre-loaded files as a first test print.

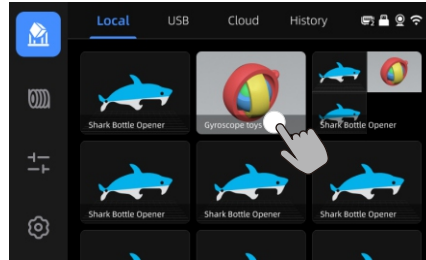
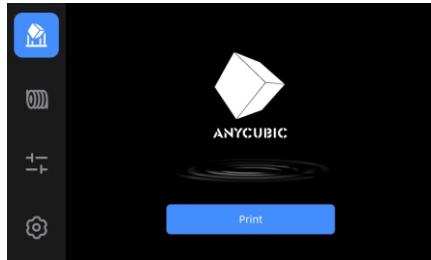

Select the model from local storage or U-DISK.

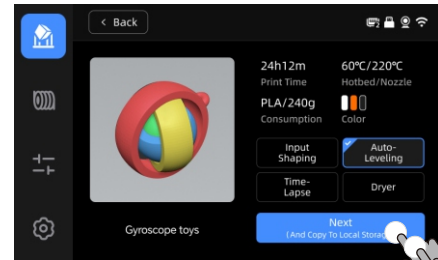

Print

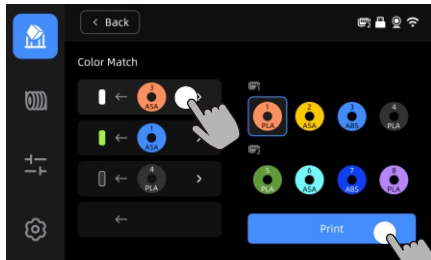

Select color, press "Print".
Color Match: Map the actual filaments to the print file preset filaments

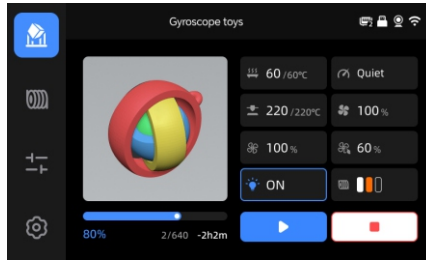

Printing in progress

Note :

1. The built-in model is subject to reality.
2. Please use similar colors to match the preset, otherwise the flush setting might be inaccurate.
3. The printer will generate high temperatures when working. Please do not touch the hot bed and nozzles with your hands.



Printer Binding

1. Please connect the printer to the network first.
2. Scan the QR code on the printer screen, QR code path: [Settings]-[Network]-[Account], download the ANYCUBIC App, register and log in to the ANYCUBIC account.
3. Open ANYCUBIC App, click [+intiate printing], click [Scan], and scan the QR code on the printer screen to bind ANYCUBIC account.

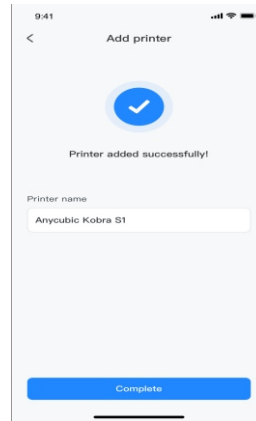
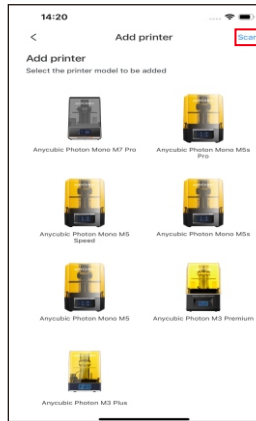
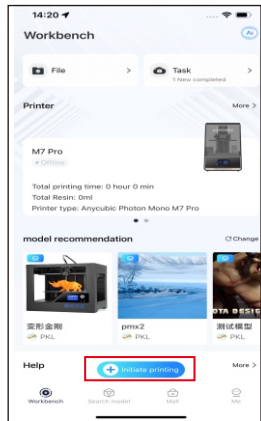
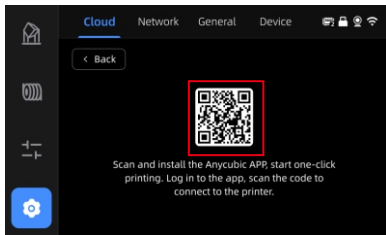

Software Installation and Binding

1. Software Installation Procedure

Open the attached USB drive and navigate into the path: \Files_English_Ancubic Kobra S1\Ancubic Slicer, choose Windows /Mac to install the corresponding version, double-click on the Ancubic Slicer application to begin the installation .

2. Please connect the printer to the network before performing the following operations.

3. Anyubic Slicer Usage Instruction:

Open the attached USB drive and navigate into the path: \Files_English_Ancubic Kobra S1 combo\Ancubic Slicer \Ancubic Slicer_Usage Instructions

- ① After the software installation is completed, enter the main interface and click **[Workbench]** or **[Login to begin remote print]**.
- ② If you already have an APP account, you can directly enter your account and password to log in. If not, click **[Sign Up Now]**.

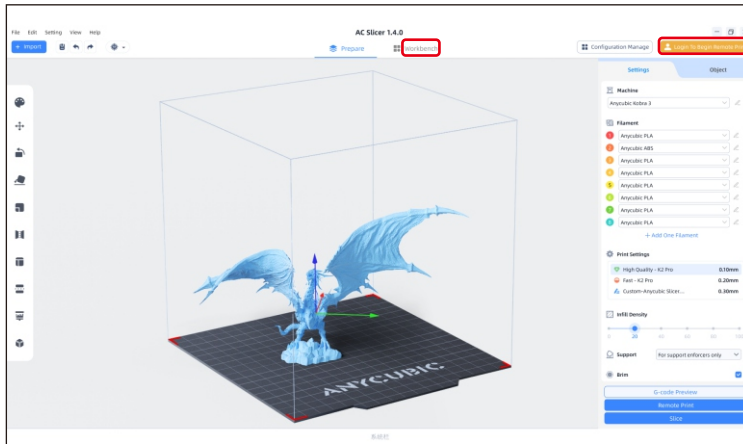

Software Installation and Binding

③ Click [Add Printer].

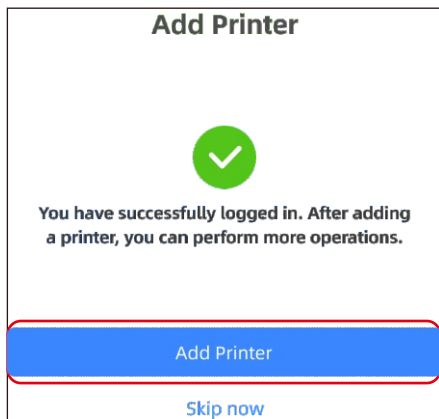

④ Automatically find printers on the same LAN as the current device. If the APP has been bound to the machine and logged in to the same account, the information will be automatically synchronized.

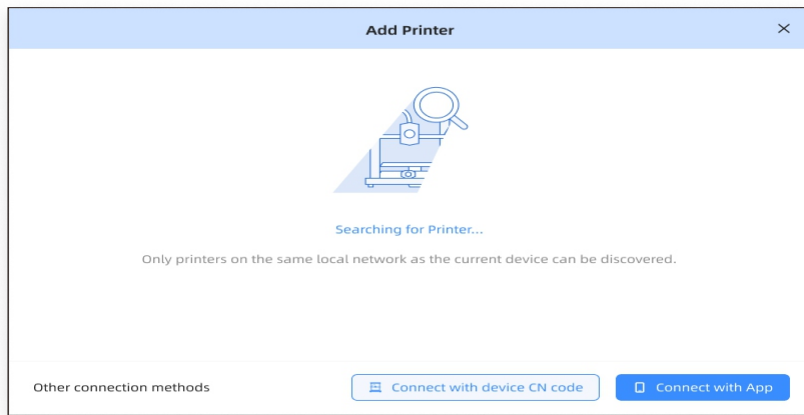

Software Installation and Binding

- ⑤ Select the machine that needs to be bound in the automatic search results and click **[Add Now]**. Multiple printers can be connected; if the search is not successful, please click **[Connect with device CN code]** or **[Connect with APP]**.

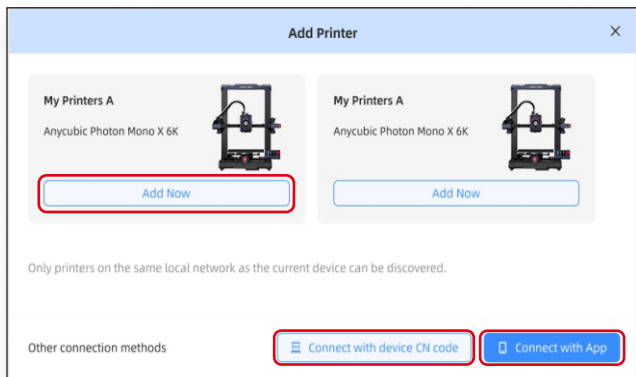

- ⑥ If the search fails, enter the CN code of the device to connect. Find the CN code path: select **[Settings-Cloud Platform -Device Information-CN Code]** on the printer.

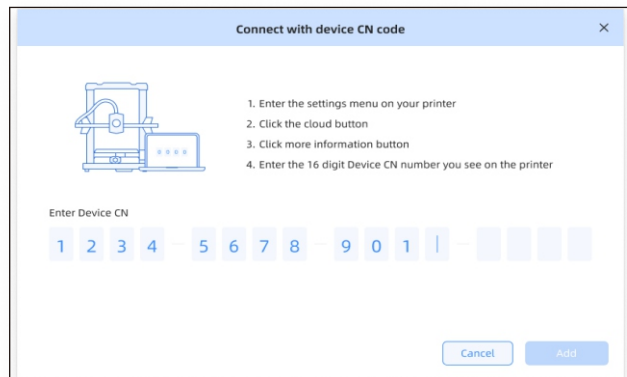

Note:

The software interface is subject to the latest version.



Other Function Descriptions

Vibration Compensation: To achieve better printing results, it is recommended to perform a vibration compensation check after printing for more than 300 hours or when the machine has been moved. This feature helps reduce the occurrence of banding during high-speed printing. Regular vibration compensation checks help maintain the stability and accuracy of the printer, thereby improving print quality.

Press "Tools" - "Calibration" - "Vibration Compensation" and wait for the machine to complete the calibration. Please do not touch the machine during the calibration process.

Filament Runout Detection: This function is designed to prevent printing failures when the filament runs out during the middle of a print. It alerts the user to replace the filament before continuing the print, effectively preventing wasted prints due to filament shortage.

Power Loss Resume: When printing using the filament holder, in the event of a sudden power outage or accidentally turning off the machine, this function does not require manual setup. Simply reconnect the power and turn on the machine. You can then resume the print.

Leveling

Press "Tools" - "Calibration" - "Auto Level". Wait for the machine to complete the leveling process.

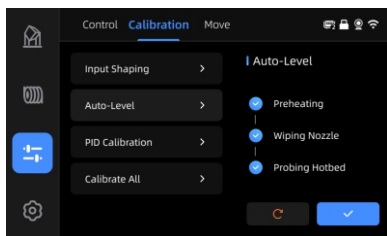
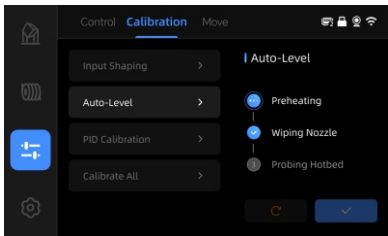
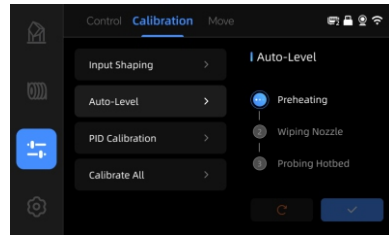
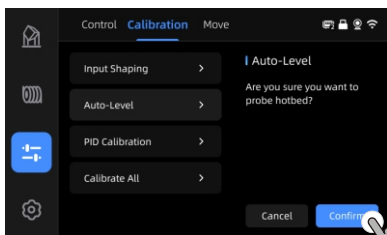
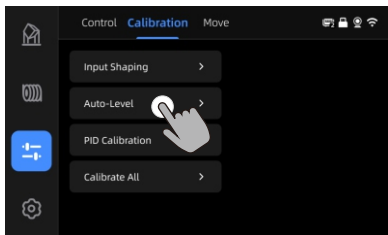

Note:

Please check whether the PEI magnetic spring board is installed before leveling.



Attention

1. Anycubic 3D printer generates high temperature. DO NOT reach inside of the printer during operation. Contact with extruded materials may cause burns.
2. Use high temperature resistant gloves when operating the product.
3. This equipment is not suitable for use in locations where children are likely to be present.
4. The fuse rating for the printer is 250V 10A. Never replace the fuse with one of a higher amperage, otherwise it may cause fire.
5. The socket-outlet shall be easily accessible.

If the above problems cannot be solved, please initiate consultation in our after-sales service system, and our engineers will reply you in the form of email within one working day.

(<https://support.anycubic.com/>)



Warm tips:

1. Fill in the information based on the SN of the corresponding model. The items with red dots are mandatory.
2. If the order is successful, you will soon receive a reply from the after-sales service system in your mailbox.
3. If you successfully place an order but do not receive an email, please watch out for spam.
4. If the order creation fails, please pay attention to the pop-up reminder on the web page.



Name:Apex CE Specialists GmbH
Add:Habichtweg 1 41468 Neuss Germany
Contact:Wells Yan
Tel:+353212066339
E-Mail:Info@apex-ce.com



Name:APEX CE SPECIALISTS LIMITED
Add:89 Princess Street,Manchester, M1 4HT,UK
Contact:Wells
Tel:+ 441616371080
E-Mail:info@apex-ce.com

FC CE RoHS



M02010079