

Photon Mono 4

[▶ User Manual](#)

Dear customer,

Thank you for choosing Anycubic products.

Maybe you are familiar with 3D printing technology or have purchased Anycubic printers before. However, we still highly recommend you read this manual carefully, as the installation techniques and precautions can help you avoid any unnecessary damage or frustration.

Please visit <https://support.anycubic.com> to contact us if you have any questions. You can also learn more information from the website, such as software, videos, models.



Anycubic support center

Copyrighted by "Shenzhen Anycubic Technology Co., Ltd ", all rights reserved.

Team Anycubic

Safety Instructions

Always follow the safety instructions during assembly and usage, to avoid unnecessary damage to the 3D printer or individual injury.



Please contact our Customer Service if you have any issues after receiving the products.



In case of emergency, please immediately cut off the power of the 3D printer and contact our technical support.



UV light is harmful to the eyes; please avoid direct contact. When operating, wear protective equipment such as anti-UV goggles and gloves.



Anycubic 3D printer includes components that can cause injury.



Be cautious when using the scraper, and make sure to orient the sharp parts of machine and tool away from people.



Keep the Anycubic 3D printer and its accessories out of the reach of children.



Vapors or fumes may be irritating at operating temperatures.

Always use the Anycubic 3D printer in an open and well ventilated area.



Do not expose Anycubic 3D printer to any water or rain environment.



Use Anycubic 3D printer in an environment with a temperature of 8°C-40°C and a humidity of 20%-50%. For optimal performance, do not exceed this range. Also, avoid direct sunlight exposure.



Do not disassemble Anycubic 3D printer, please contact technical support if you have any questions.



Contents

1. Product Overview	5
2. In the Box	6
3. Technical Specification	7
4. Recommended Print Parameters	8
5. Menu Directory	9
6. Preparations	12
7. Start Printing	15
8. Resin Recycling	16
9. Resin Exposure Range Finder	17
10. Machine Maintenance	19
11. FAQ	20

Product Overview

The pictures are for reference only. Please comply with the actual products.

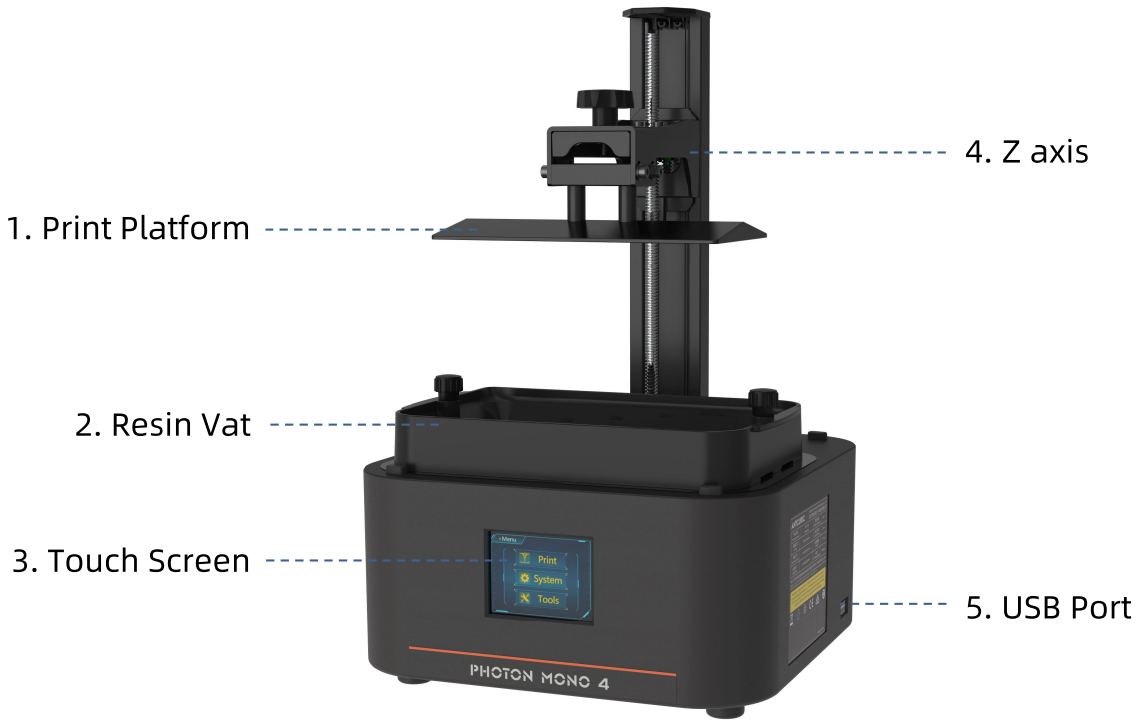

In the Box

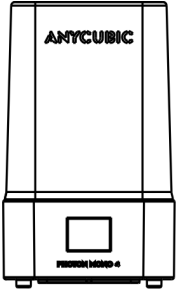

Photon Mono 4

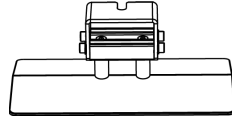

Print platform * 1



Resin vat * 1



Screen protector kit



Hex key set



Protective equipment

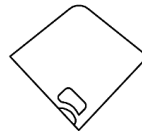

Filter*5

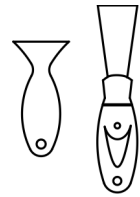

Scraper * 2



Leveling paper * 1

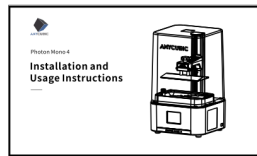

Manual * 1



USB drive * 1

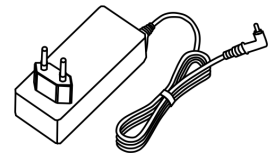

Power adaptor

Operating System

System	Photon Mono 4
Touch Screen	2.8-inch Resistive Screen
Software	Anycubic Photon Workshop (also compatible with other software)
Connectivity	USB Drive

Specifications

LCD screen	7 inch 10K
Light source	Matrix LED light
XY Resolution	9024*5120
Z axis Accuracy	0.01 mm
Suggested Layer Thickness	0.01 ~ 0.15 mm
Power Adapter Output	24V =2.5A

Physical Dimensions

Dimension	230 mm(L) *235 mm(W) *391 mm(H)
Build volume	153.4 mm(L) *87 mm(W) *165 mm(H)
Weight	4 kg

Recommended Print Parameters

Layer Thickness	0.05 mm
Normal Exposure Time	2.8 s
Off Time	1 s
Bottom Exposure Time	30 s
Bottom Layers	5
Z Lift Distance	6 mm
Z Lift Speed	4 mm/s
Z Retract Speed	6 mm/s
Anti-alias	1

--The data above roots in Anycubic lab, only for reference.

Menu Directory

Home menu



Print

System

Tools

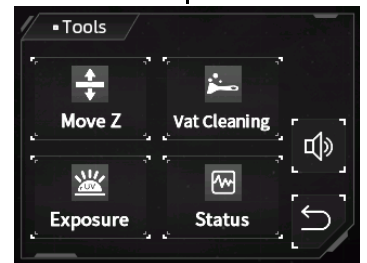
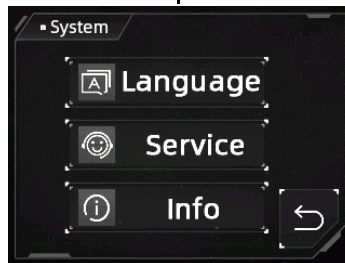
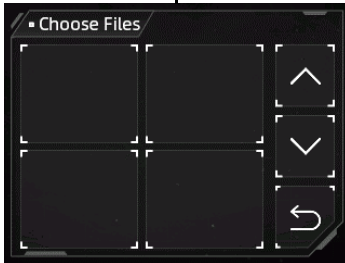

Print

Choose Files:

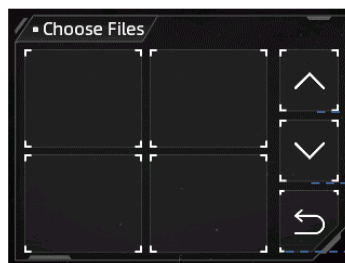

Page up

Page down

Return to the Home Menu

File:

Click a file

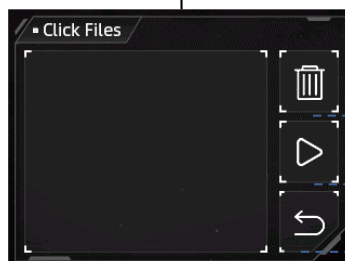

Delete the current file

Click to start printing

Return to the Print Menu

System

Language: Switch to English/Chinese

Service:

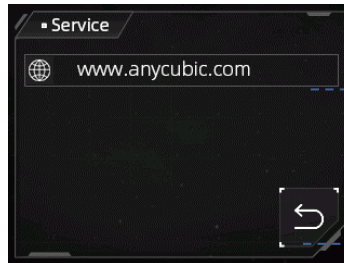

Official website

Return to the System Menu

Information:

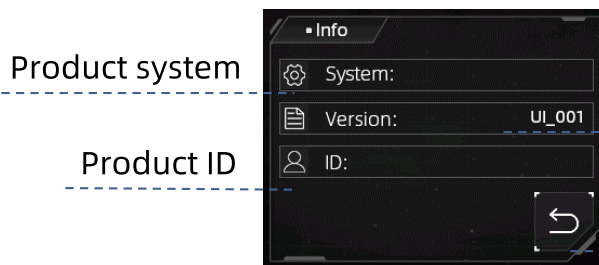

Product system

System version

Product ID

Return to the System Menu

Tools

Move Z:

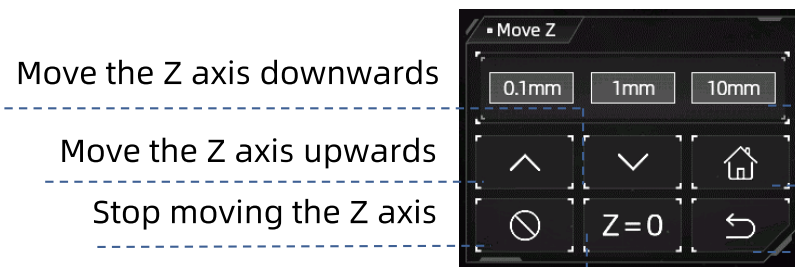

Move Z by 0.05mm
/1mm/10mm/50mm

Return to Zero

Return to the Tools Menu

Reset the zero point

Vat Cleaning:



The screenshot shows the 'Vat Cleaning' menu with a timer set to 30s. The timer has markers for 10s, 20s, 30s, 40s, and 50s. A 'Start' button is centered below the timer, and a 'Return to Tools Menu' button is in the bottom right corner.

Click to start exposure

Set the exposure time

Return to Tools Menu

Exposure :



The screenshot shows the 'Exposure' menu with three image thumbnails at the top. Below them are buttons for 'S', 'Next', and a 'Return to Tools Menu' button. There are also up and down arrow buttons for adjusting the test time.

Choose an image to expose

Click to set the time

Expose for the preset time

Increase the test time

Reduce the test time

Return to the Tools Menu

Status:

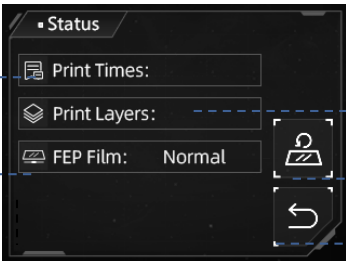

The screenshot shows the 'Status' menu with three rows of information: 'Print Times', 'Print Layers', and 'FEP Film: Normal'. There is a 'Reset Status' button (represented by a person icon) and a 'Return to Tools Menu' button in the bottom right corner.

Statistics of print times

Whether release film needs to be replaced

Statistics of print layers

Click to reset the status

Return to Tools Menu

Horn icon: Turn on/off the screen sound

Preparations

Please place the 3D printer on a stable, level workbench and operate it in an open, well ventilated area away from sunlight. Refrain from using the printer in areas with ultraviolet light sources (such as fluorescent lamps or UV disinfection lamps) to prevent poor printing results. For the first use, please follow the instruction to finish the preparations.

1. Unbox, take out the machine and its accessories, and inspect them.

2. Install the screen protector.

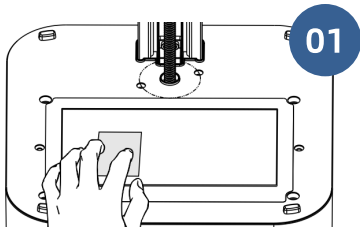

Peel off the protective film and clean the LCD screen

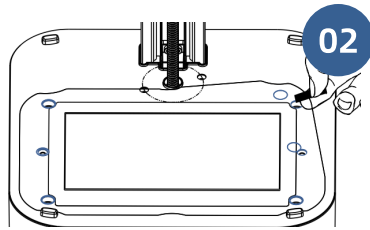

Peel off the film ①, then align with the locating holes to stick the screen protector

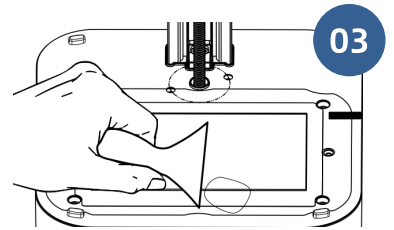

Squeeze out the air bubbles

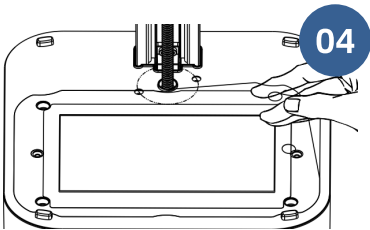

Peel off the film ②

3. Plug in power and turn on the machine.

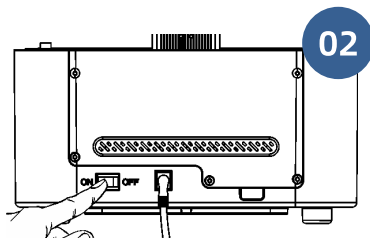
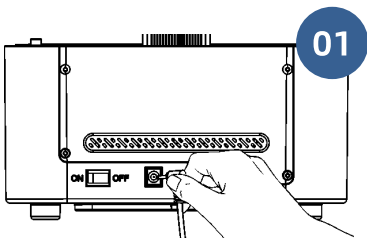

Preparations

4. Install the print platform.

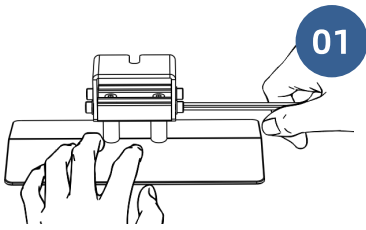

Loosen the four screws on the print platform

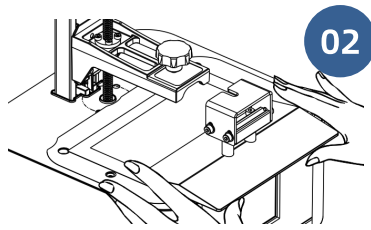

Push the platform onto the platform carrier

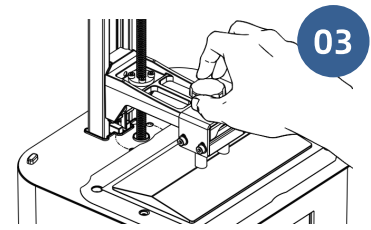

Tighten the knob

5. Leveling.

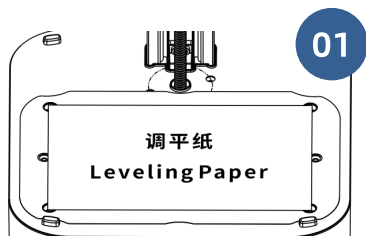

Place the leveling paper on the curing screen

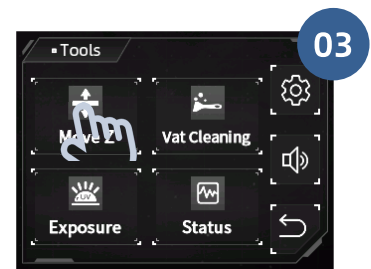
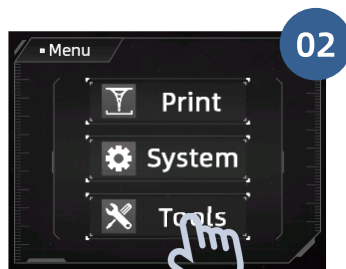

Click "HOME"

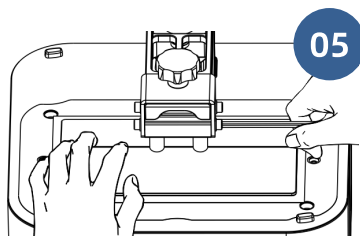

Press the platform gently, tighten the four screws

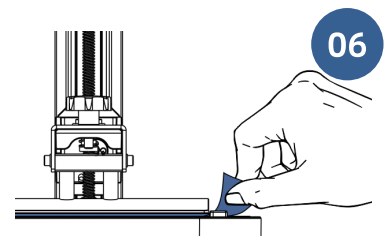

When pulling the leveling paper, there is a significant resistance or it cannot be pulled out

6. Set the zero position.

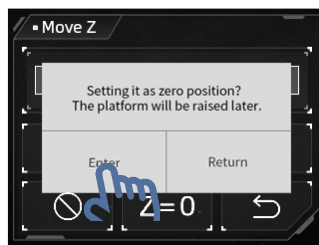

Preparations

7. Choose an exposure image to test after the platform stops moving.



8. Install the resin vat.

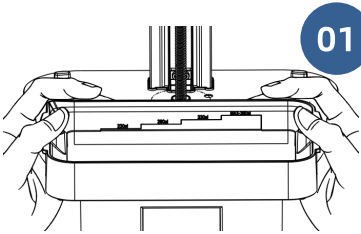

Put the resin vat with its feet stuck in locating holes

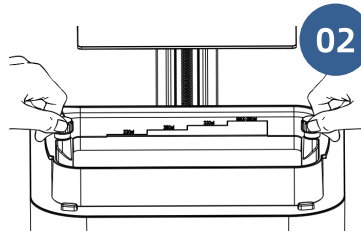

Tighten two knobs

It is suggested to wear gloves and a mask for subsequent operations, as the contact with resin or the smell of the resin may cause your discomfort.

9. Please check the release film. If the film is broken, replace it immediately to avoid further damage to the machine.

10. Slowly pour the resin into the vat and make sure it is within the vat's maximum scale.

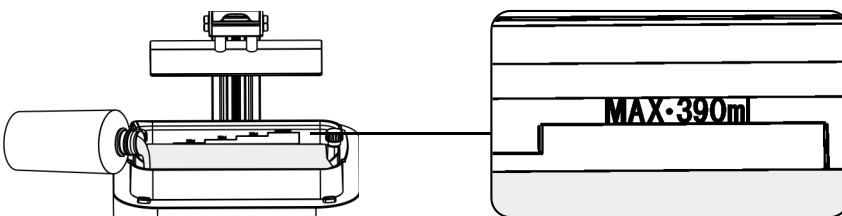

11. Put on the cover.

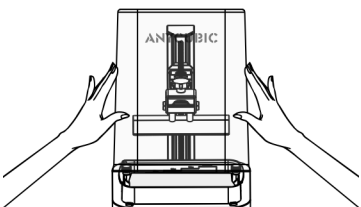

Start Printing

The included USB drive provides a slice file that can be used for printing test. The R_E_R_F file is to find out the optimal exposure parameters for different resins. For more details, please refer to “Resin Exposure Range Finder” chapter.

1. Insert the USB drive to the right USB port.

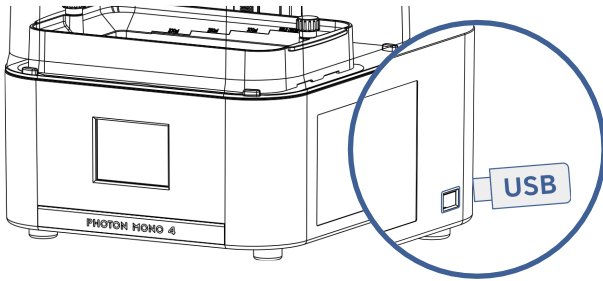

2. Then, choose a file to print.



Notes:

- ① It's recommended that use the USB drive we provide. Otherwise, please use a USB drive whose memory size **does not exceed 32G** and ensure that it's formatted to **FAT/FAT 32**.
- ② The print files should be placed at the root directory of USB drive to avoid read errors.

Resin Recycling

1. After printing, remove the platform when resin stop dropping from the platform. Remove the model by metal scraper and then wash it with 95% alcohol or other detergent. Then, dry and post-cure the model.

2. Please enable the vat cleaning function when the resin is partially cured to remove the residue. Otherwise, it may cause damage to the release film or LCD screen.



Remove resin sheet
by plastic scraper

3. If there is any remaining resin, please pour it out through a vat spout and recycle it with a filter and a funnel. The model file of funnel is saved in the included USB drive, please print the model according to your personal requirements.

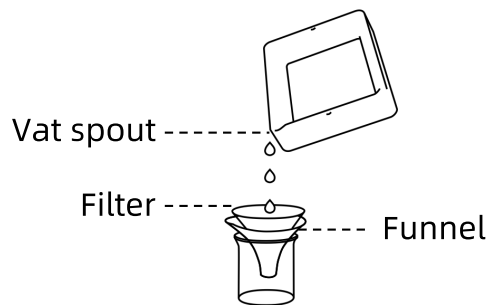

4. If you do not use the 3D printer for a long time, please clean the resin vat timely and store the resin in an airtight container away from light.

Resin Exposure Range Finder

“R_E_R_F” is an abbreviation for “Resin Exposure Range Finder” . This function is used to find out the optimal exposure parameters for different resins.

1. Import the R_E_R_F file which is saved on USB drive into the slicing software. There are eight models in the file. The exposure time for model 1 is equal to "normal exposure time (s)" of the file, and the exposure time for other models will be increased by an increment of **0.25 s**.

For example:

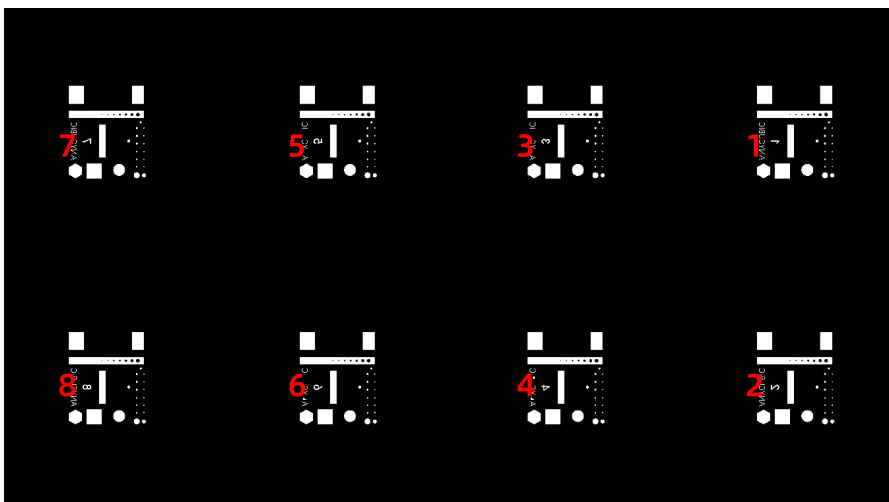

The numbers on the models indicate their order

2. According to the personal requirement, adjust the exposure time of the models by modifying "normal exposure time (s)" of the file. When exposure time for Model No. 1 is changed, the exposure time for other models will be increased by an increment of **0.25 s**.

For example, when normal exposure time is set to 1.5 s, the exposure time for Model No.1-8 is: 1.5 / 1.75 / 2 / 2.25 / 2.5 / 2.75 / 3 / 3.25 s.

3. After printing, remove and clean the models. Compare the print effect of models and choose the model's exposure time that meets your needs as the print parameter. Take a comparison of model A&B as an example.

Resin Exposure Range Finder

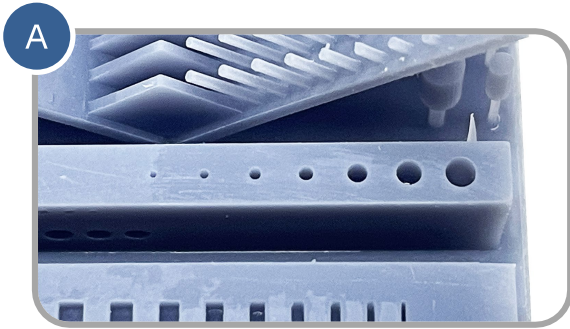

More holes

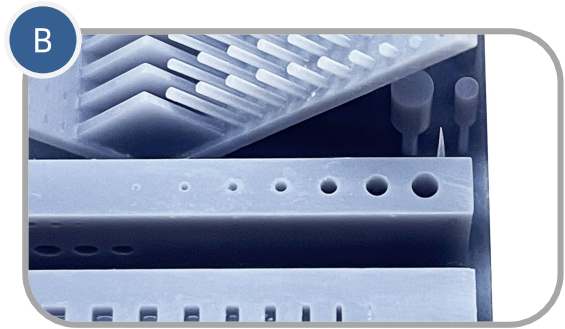

Less holes

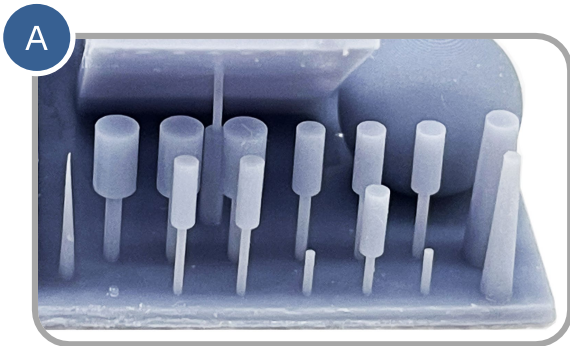

Less cylinder

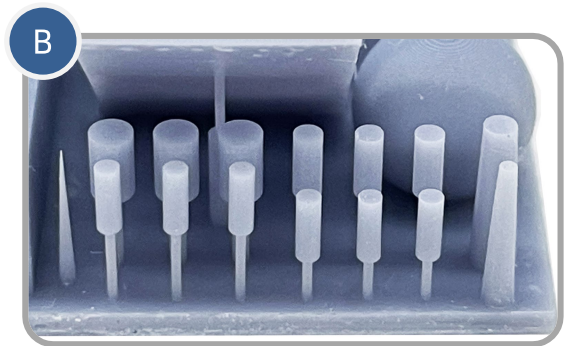

More cylinder

- Model A has more holes and fewer cylinder. If you print by the parameter of model A, more details of model can be printed with high risk of failure.
- Model B has fewer holes and more cylinder. If you print by the parameter of model B, model may be printed successfully yet with some details lost.

In addition, you can compare the bridges, needles or other parts to choose a proper model and find the parameter. If none of them can be chose, adjusting the "normal exposure time (s) " is suggested.

Notice: DO NOT change the file name of "R_E_R_F" , because Anycubic 3D printer can only recognize THIS file name to run this function. Also, do not name other file as "R_E_R_F" .

Resin vat maintenance

- **Remove the cured resin from release film:** Click Vat Cleaning and then remove the cured resin sheet to protect the film. Do not use sharp objects to scrape off the residues on the film.



Remove resin sheet
by plastic scraper

- **Release film replacement:** The statistics of print times and print layers are shown in Status interface. Please check them and replace release film timely to avoid print failure or even the damage to printer.

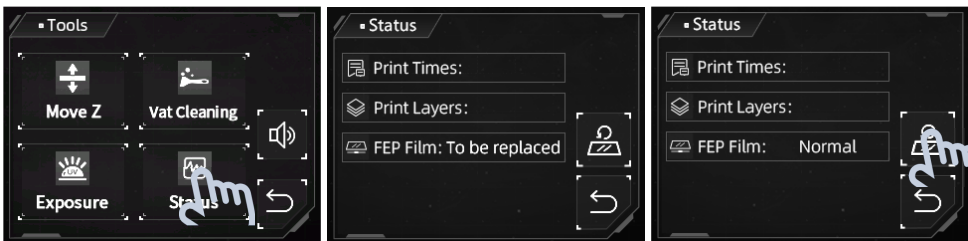

Replace release film
at this time

Click reset button
after replacement

- If you do not use the resin for over two days, store it in an airtight container away from light.
- If resin is stained on the resin vat, wipe it off timely.

Z axis maintenance

If Z axis makes a noisy sound, please apply lubricant to Z lead screw.

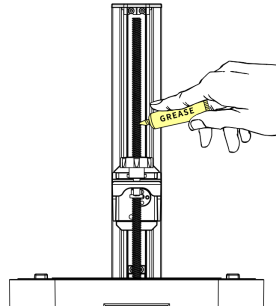

Cleaning

- **Clean the print platform:** Clean platform with alcohol and paper towel.
- **Protect LCD screen :** If the resin cured on screen protector, please replace it immediately to protect LCD screen.
- **Clean the body of printer:** Clean the body of the printer with alcohol.

Complete the initial trouble shooting steps by referring to the following proposed solutions, or contact our technical support for additional assistance.

1. Model do not stick to platform

- Bottom exposure time is insufficient. Please increase the exposure time.
- Contact area between the model and platform is small. Please add a raft.
- Bad leveling.

2. Layer separation or splitting

- The machine is not stable during printing.
- The release film is not tight enough or needs a replacement.
- The printing platform or resin vat is not tightened.
- The lift speed is too fast.
- The model is hollowed without punching.

3. Layer shift

- Add supports.
- Reduce the lift speed.

4. Floccules left in resin vat or attached to models

- The exposure time is too long. Reduce the normal exposure time and bottom exposure time.

Thank you for purchasing Anycubic products! Under normal usage and service, the products have a warranty period of up to one year. Please visit Anycubic support center(support.anycubic.com/en) to report any issues with Anycubic products. Our professional after-sale service team would respond within 24 hours and solve the issues.